

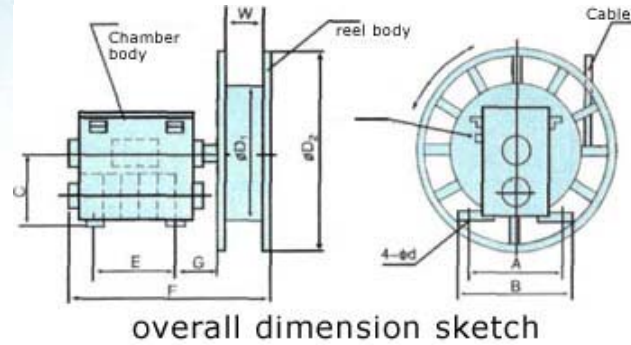

magnetonmove.com

## Overhanging Cable Reel Model Series JT



Overall dimension table

Contour items	A	B	C	D1	D2	d	E	F	G	W	(kg) Mass
1	410	450	462	800	1300	18	520	1010	105	250	360
2	410	450	462	1000	1300	18	520	1010	105	250	380

Main technical data

Cable Model	Enabled Current		50m Series	Contour Item	60m Series	Contour Item	70m Series	Contour Item	80m Series	Contour Item	100m Series	Contour Item
	Continuously	I min. On /Off										
YC 3×25+1×10	91	125		1	JTC125 -60-4-III	1	JTC125 -70-4-I	1				
					JTD125 -60-4-III		JTD125 -70-4-III					
YC 3×35+1×10	113	150	1	1	JTC150 -60-4-III	1	JTC150 -70-4-III	1				
					JTD150 -60-4-III		JTD150 -70-4-III					
YC 3×50+1×16	140	190	1	1	JTC190 -50-4-I							
					JTD190 -50-4-III							
UC 3×35+1×6+4×4	110	150	1	1	JTC150 -50-8-III	1	JTC150 -60-8-III					
					JTD150 -50-8-III		JTD150 -60-8-III					

CRHF 10×2.5	12	20			JTC20-60-10-1	1	JTC20-70-10-Ⅲ	1				
					JTD20-60-10-Ⅲ		JTD20-70-10-I					
CRHF 12×2.5	12	20			JTC20-60-12-I	1	JTC20-70-12-I	1				
					JTD20-60-12-I		JTD20-70-12-I					
YC 3×10+1×6	50	65							JTD65-80-4-I	2	JTD65-100-4-Ⅲ	2
YC 3×16+1×6	60	85						JTD85-80-4-I	JTD85-100-4-Ⅲ			

**Attentions for model selection:**

1. This series reel shall only be used for installation pattern CD shown in the sketch on Page 30.
2. This series reels are also available for the other installation patterns shown in the sketch on Page 30. We can design the model according to the requirements by the customers.
3. The cables are provided by the customer.

©Copyright 2007 YUXIANG Magnetic Materials Ind. Co.,Ltd.All Rights Reserved.