



magnetonmove.com

Lifting Electromagnet Model Series MW12 for Handling Bundled Bar Materials

Applications:

This product series is designed as strong permeable magnetic circuit which can penetrate several layers of airspace; suitable for lifting and transferring bundled bar materials as well as heavy duty steel ingots or steel moulds.

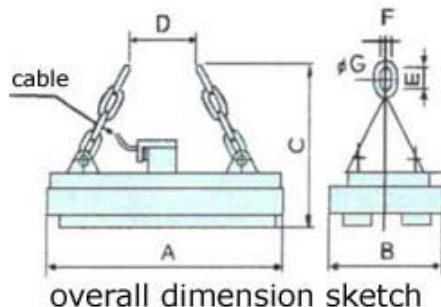

Main technical data

DC-220V, TD-60%

Model	overall dimension (mm)							Mass (kg)	current (A)	power (kw)	Examples for lifting capacity four units				
	A	B	C	D	E	F	G				(mm) Bar material Diameter	(mm) Single bundle diameter	(mm) Length	(T) Weight per bundle	Bundle amount for lifting
MW12-11590L/G	1150	890	800	300	160	90	28	1450	32	7	φ 16-51	4)300	9-12	2	3
MW12-14090L/G	1400	870	900	400	160	90	28	1700	41	9	φ 16-51	4)300	9-12	2	4
MW12-70100L/G	700	1000	800	300	160	90	28	1250	20	4.5	φ 10-32	4)300	9-12	2.5	2
MW12-10090L/G	1000	900	800	300	160	90	28	1400	30	6.5	φ 10-32	4)300	9-12	2.5	3
MW12-11090L/G.	1100	900	900	300	160	90	28	1500	32	7	φ 9-32	φ 300	9-12	3	3
MW12-15090L/G	1495	924	1045	650	210	120	30	2200	39	8.6	φ 12-40	φ 250-300	9-12	3	4
MW12-180100L/G	1800	1060	1450	650	210	120	30	2500	50	10.2	φ 12-40	φ 300-360	9-12	3	4

©Copyright 2007 YUXIANG Magnetic Materials Ind. Co.,Ltd.All Rights Reserved.