



magnetonmove.com

Vibration Electromagnetic Separator

Applications:

MCF series vibration electromagnetic separator is a new kind of discharging iron equipment produced by our company, which can separate non-magnetic powder materials (60-300holes/inch) in the aim of raising purity of raw materials. The series products are extensively used in abrasive, fireproof material, ceramic, glass, chemical industries and etc.

Feature:

1. Material through magnetic separation of many layers with good separating iron performance.
2. Raw material handled in closing state, may prevent dust rising.
3. Suitable for auto-production on an assembly line and auto-handling raw material continually.
4. The separator structure simple, maintenance convenient and small area covered.

Working principle:

After DC electrify in excitation wiring, the material net around produce non-even magnetic field, attracted iron grain from raw material and non-magnetic material even through vibration motor so as to reach aim of getting of iron.

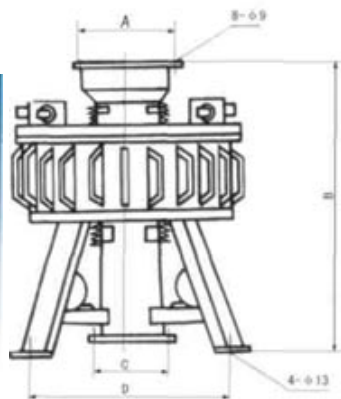

Main technical data

Model	MCF-15L	MCF-25L	MCF-30L	MCF-30T
excitation (kw)	0.67	1.89	2.36	10.5
vibration power (kw)	0.2×2	0.25×2	0.5×2	0.5×2
Working bore (mm)	150	250	300	300
ma.x handling capable (t/h)	1000	1500	3000	3000
Mass (kg)	400	600	800	5500
Commutation Controlling unit	SSTM-1.5-D	SSTM-3.1D1-D	SSTM-3.1D,-D	SSTQ-12D1-D

©Copyright 2007 YUXIANG Magnetic Materials Ind. Co.,Ltd.All Rights Reserved.